

1. GENERAL INFORMATION

Tilt angle sensor can be employed for measuring inclination angles in control and navigation systems.

2. STRUCTURE AND OPERATING PRINCIPLE

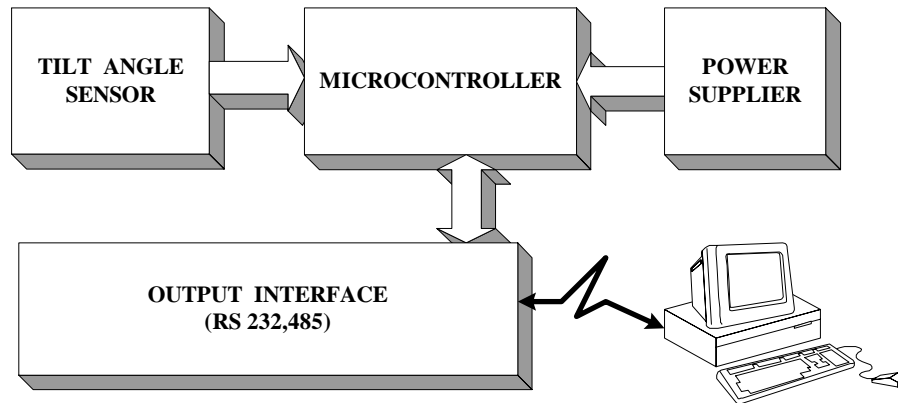

Figure 1

The sensing device uses a biaxial accelerometer as a sensing element which is fabricated by using micromechanics technology. The microcontroller built in the sensing device serves for determination of the tilt angle and organization of exchange with computer or other device via RS232/RS485 channel.

The tilt sensor has a metallic body with reference surfaces and mounting holes.

3. PERFORMANCE SPECIFICATION

Model	RF711
Measurement range, degrees	± 90
Output interface	RS232, 485
Measurement error, angular minutes	30
Supply voltage, V	5-12
Enclosure rating	IP65
Operating temperature, °C	-40..+50
Dimensions, mm	80x40x36



4. EXAMPLE OF ITEM DESIGNATION WHEN ORDERING

RF711-N-TTT

Symbol	Name	Value	Description
N	Number of connectors	0	without connector
		1	one connector
		2	two connectors
-TTT	Output interface	232	RS232.
		485	RS485.

5. TYPE OF OUTPUT INTERFACE

5.1. RS232, RS485 - type

Operation modes and configuration parameters.

Measurement data from encoders can be obtained through serial interface and/or on the analog current output. Through the serial interface measurement data can be obtained by both single requests (inquiries) and by automatic data streaming

The nature of operation of the encoder governs its configuration parameters, which can be changed by transmission of commands through serial port.

5.1.1. Sampling period

Sampling period — specifies the time interval for automatically refreshment of measurement results by the encoder. The value of the time interval is set in increments of 0.1 ms. If serial interface is used to receive the result and the time intervals set are small, the time required for data transmission at the selected data transfer rate should be taken into account. If the transfer time exceeds the sampling period, it wills this parameter, which will determine the data transfer rate.

5.1.2. Number of averaged samples

The encoder controller performs sampling of displacement counter readings every 50 μ s. Number of averaged values — specifies the number of source results to be averaged for deriving the output value. Source data are stored in a circular buffer, and new mean value is calculated each time the new result arrives; therefore, the output may regarded as a moving average.

5.2. Description of serial interface

The hardware port RS232 allows encoder to be connected directly to a computer.

In accordance with network capabilities of the RS485 standard, the implemented serial data communications protocol permits connection of several encoders to one information collection unit through a ‘common bus’ circuit

5.2.1. Data communications protocol

Network data communications protocol assumes the presence of ‘master’ in the net, which can be a computer or other information-gathering device, and from 1 to 127 ‘slaves’ (RF701 Series encoders) which support the protocol. Each ‘slave’ is assigned a unique network identification code



– a device address. The address is used to form requests or inquiries all over the net. Each slave receive inquiries containing its unique address as well as ‘0’ address which is broadcast-oriented and can be used for formation of generic commands, for example, for simultaneous latching of values of all encoders and for working with only one encoder (with both RS232 port and RS485 port).

Serial data transmission format:

1-start bit,8-data bits,1-odd bit,1-stop bit.

Odd bit is complementary to 8-data bits for oddness.

The communications protocol is formed by communication sessions, which are only initiated by the ‘master’. There are two kinds of sessions:

- 1) ‘inquiry’,[‘message’] — [‘answer’], square brackets include optional elements
- 2) ‘inquiry’ — ‘data stream’ — [‘inquiry’].

‘Inquiry’ (INC) is consisting of two messages one-byte message INCA and INCB. First from that, INCA contains 7-bit device address ADR(6:0), and it is the only one of all messages in a session where most significant bit is set at 0; therefore, it serves to synchronize the beginning of the session. Second message INCB contains 7-bit inquiry code MSG(6:0). The ‘inquiry’ format:

INCA(7:0) = 0,ADR(6:0)
INCB(7:0) = 1,MSG(6:0).

‘Message’ and ‘answer’ are data bursts that can be transmitted by ‘master’ or by ‘slave’ in the course of the session, respectively. ‘Data stream’ is a infinite sequence of data bursts or batches transmitted from ‘slave’ to ‘master’ which can be interrupted by a new inquiry. In transmission of ‘data stream’ one of the ‘slaves’ fully holds data transfer channel, therefore, when ‘master’ produces any new inquiry sent to any address, data streaming process is stopped. Also, there is a special inquiry to stop data streaming.

All messages with a data burst contain 1 in the most significant digit. Data in a message are transferred in tetrads. When byte is transmitted, lower tetrad goes first, and then follows higher tetrad. When multi-byte values are transferred, the transmission begins with lower byte.

The following is the format of two ‘message’ data bursts for transmission of byte DAT(7:0):

Dt0(7:0);Dt1(7:0) = 1,0,0,0,DAT(3:0); 1,0,0,0,DAT(7:4).

When ‘answer’ is transmitted, the message contains three additional bits of cyclic binary batch counter (CNT). Bit values in the batch counter are identical for all sendings of one batch. The value of batch counter is incremented by the sending of each burst and is used for formation (assembly) of batches or bursts as well as for control of batch losses in receiving data streams. The following is the format of two ‘answer’ data bursts for transmission of byte DAT(7:0):

Dt0(7:0);Dt1(7:0) = 1,CNT(2:0),DAT(3:0); 1,CNT(2:0),DAT(7:4).

5.2.2. Types of inquiries

Inquire code	Description	Message (size)	Answer (size)
01 _h	Device identification	—	-device type = 711h (3) -modification = 0h (1) -serial number (4)
02 _h	Reading of parameter	-code of parameter (2)	-value of parameter (*)
03 _h	Writing of parameter	-code of parameter (2) -value of parameter (*)	—
04 _h	Storing current parameters to FLASH-	-constant AAh (2)	-constant AAh (2)



memory			
04 _h	Recovery of parameter default values in FLASH-memory	-constant 69h	(2) -constant 69h (2)
05 _h	Latching of current result	—	—
06 _h	Inquiring of result	—	-result (4)
07 _h	Inquiring of a stream of results	—	-stream of results (4)
08 _h	Stop data streaming	—	—

(*the size is determined by the parameter dimension see. p.5.2.3

5.3.3. List of parameters

Code of parameter	Size (tetrad)	Name	Values
00 _h	2	Transducer status word	Contains encoder status and error flags
01 _h	2	Network address	1...127 (default — 1)
02 _h	2	Rate of data transfer through serial port	1...192, (default — 4) specifies data transfer rate in increments of 2400 baud; e.g., 4 means the rate of 4×2400=9600baud.
03 _h	4	Sampling period	10...65535, (default — 1000) specifies the time interval in increments of 100 μs with which sensor automatically communicates the results on streaming inquiry
04 _h	2	Number of averaged values	1...128, (default — 1)
05 _h	1	Discreteness, D	1...10 (default — 10) specifies the number of increments per 1 degrees

NOTE:

All values are given in binary form.

The result value (G) transmitted by the encoder is set in increments in accordance with the discreteness parameter (D), therefore the result expressed in degrees obtained by the following formula:

$$X = G / D \text{ (degrees).}$$

On special inquiry (05h), the current result can be latched in the output buffer where it will be stored unchanged up to the moment of arrival of request for data transfer. This inquiry can be sent simultaneously to all encoders in the net in the broadcast mode in order to synchronize data pickup from all sensors.

When working with the parameters, it should be borne in mind that when power is OFF the parameter values are stored in nonvolatile FLASH-memory of the encoder. When power is ON, the parameter values are read out to RAM of the encoder. In order to retain these changes for the next power-up state, a special command for saving current parameter values in the FLASH-memory (04h) must be run

5.2.4. Examples of communication sessions

- Condition: request for device identification, device address—1, device type —701h, modification —0h, serial number —0402 (0192h), burst number —1.
 Inquiry (“master”) — 01h, 81h;
 Answer (“slave”) — 91h, 90h, 97h, 90h, 92h, 99h, 91h, 90h



- 2) Condition: Request for reading of parameter, device address —1, parameter code —05h, parameter value —04h, burst number —2.
 - Inquiry (“master”) — 01h, 82h;
 - Message (“master”) — 85h, 80h;
 - Answer (“slave”) — A4h, A0h
- 3) Condition: Request for result, device address —1, result value — 0002A5h, dimension of the result — 3, burst number —3.
 - Inquiry (“master”) — 01h, 86h;
 - Answer (“slave”) — B5h, BAh, B2h

6. POWER SUPPLY AND INTERFACE CONNECTION

6.1 RS232 interface

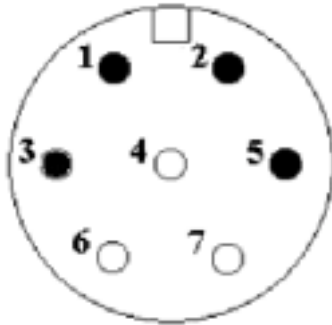

Figure 2

Number	Description
1	Rxd - input RS232;
2	Txd – output RS232;
3	U+ - supply voltage, 5...12V;
5	0V - “0” power supply;

6.2. RS485 interface

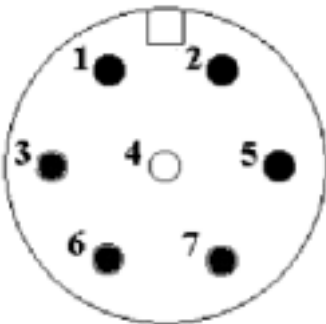

Figure 3

Number	Description
1	DI - input RS485;
2	DI+ - input RS485;
3	U+ - output, 5...12V;
5	0V - “0” power supply;
6	DO+ - output RS485;
7	DO - output RS485;

7. DIMENSIONS



with two connectors



without connector



with one connector

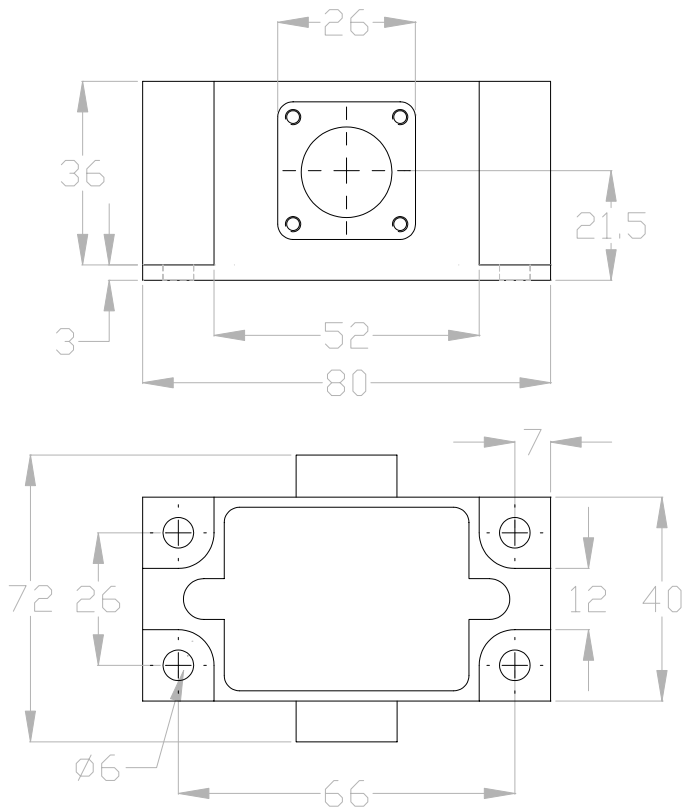

Figure 4

8. INSTALLATION PROGRAM

8.1. The "RF701,711-SP" software is intended for:

- 1) testing and demonstration of operation of incremental encoders of RF20X Series;
- 2) setting parameters of encoders;

8.2. Upon starting the program the working window appears:

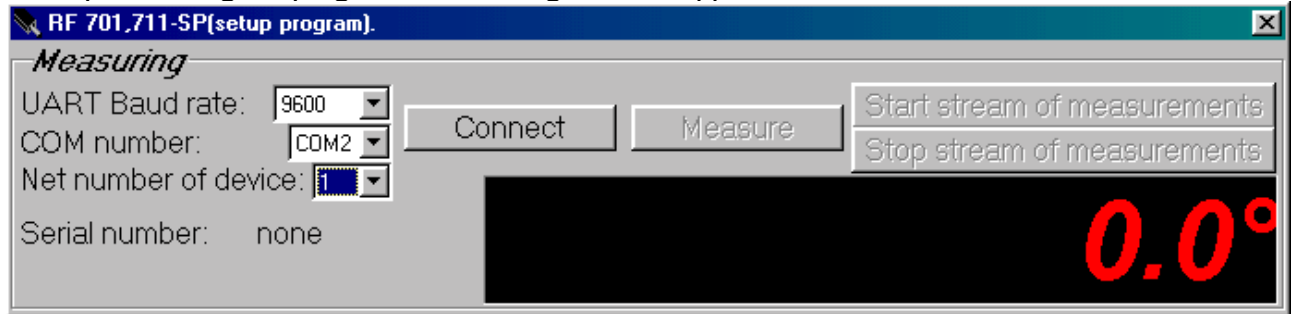

1. In the line "UART Baud rate" select encoder operation speed (factory setting – 9600 bit/s),
2. In the line "COM number" select PC RS232 port number where encoder is connected.
3. The line "Net number of device" defines sensor network address (factory setting for all sensors – "1")
4. Upon clicking the "Connect" button, RF701,711-SP will attempt to establish communication with encoder with parameters selected as above. If it fails, a 'communication error' message is displayed.
5. If communication is successfully established:
 - 1) In the line "Serial number", a serial number of the encoder is displayed
 - 3) The window changes its form to the following:

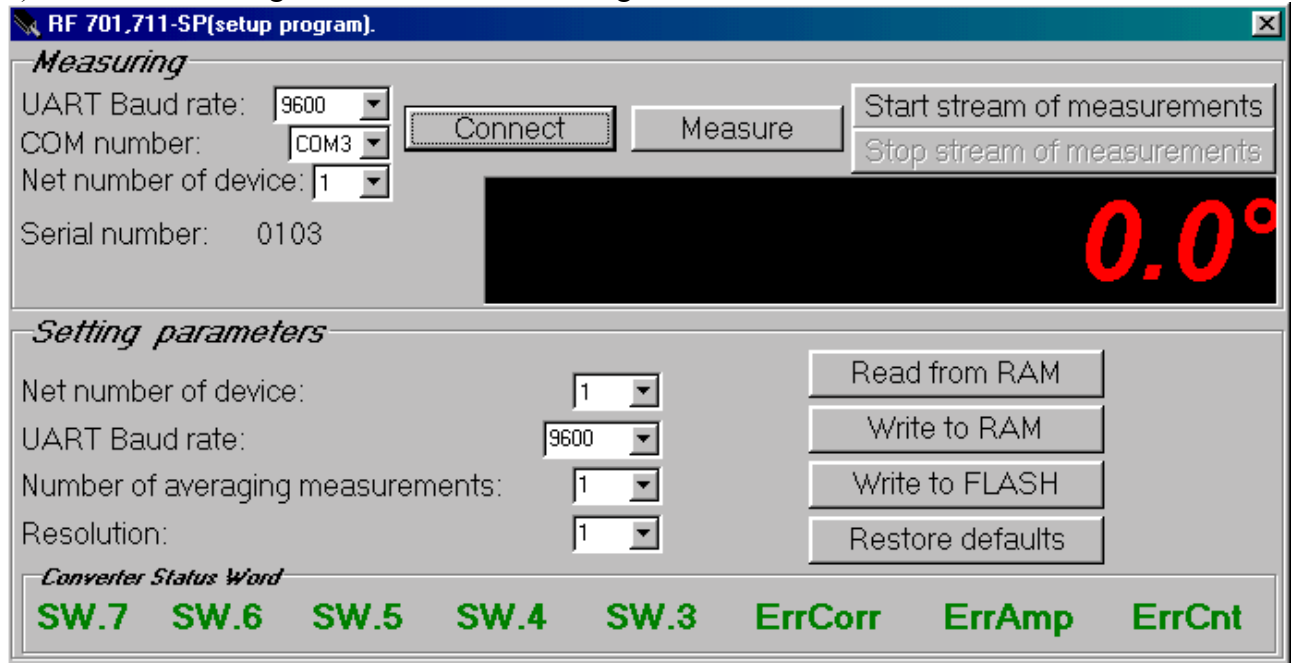



8.3. After communication has been successfully established, it is possible to check encoder performance. To do so:

1. Press the "Measure" button. As a result, the button name changes to "Stop", and measurement-on-inquiry mode is started. Measured value is sent to the display field. To cancel this mode, "Stop" should be pressed.
2. Clicking the "Start stream of measurement" button activates continuous measurement mode (data streaming mode).
3. Clicking of the "Stop stream of measurement" button deactivates the data streaming mode.

8.4. Setting parameters of the sensor

The "Setting parameters" window makes it possible to edit and enter the relevant encoder parameters to RAM and FLASH-memory.

1. In the line "UART Baud rate", select preferred data exchange rate for the encoder.
2. In the line "Number of averaging measurements", select the number of measurements to be averaged directly by the encoder. Factory setting – "1".
3. In the field " Resolution (Increment) ", set counting discreteness of the encoder.
4. In the field " Condition word of Gauge", status of the encoder flags is shown.
5. Having finished setting of required parameters, click the "Write to RAM" button.
6. Test encoder performance with a new set of parameters according to 8.3.
10. To store the new parameters in the encoder memory, click the "Write to FLASH" button. The encoder will operate with these parameter settings in subsequent activations.